

Sliding clamp for square bars, knob orange

Item description/product images

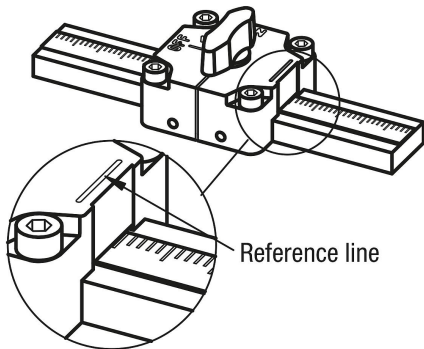

Displacement on static load from one direction

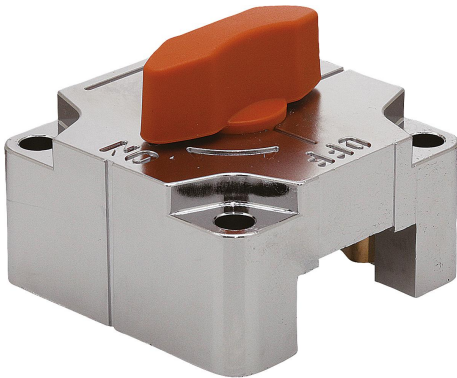
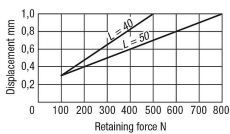

The forces apply to steel or stainless steel square material

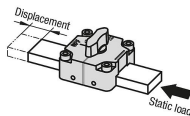

Description

Material:

Housing die-cast zinc.
Knob thermoplastic PA (polyamide).
Pins and wedge stainless steel.
Leaf spring phosphated bronze.

Version:

Housing chromed.
Knob orange, glass-bead reinforced.
Pins and wedge bright.

Note:

By turning the knob, the pins mounted in the bottom section of the sliding clamp are drawn together by the springs and forced downwards. The two pins press against the surface and fixate the sliding clamp.

Accessory:

Base plates K1073.
Scales stainless steel K0759.

Functional principle:

The sliding clamps have 2 different operating principles.

Operating principle 1:

The sliding clamp is movable.

The sliding clamp is bolted onto a base plate (K1073), loose plate or block placed under a fixated rectangular bar. The sliding clamp together with the plate or block can be slid up and down the fixated bar.

Operating principle 2:

The sliding clamp is fixated.

The sliding clamp is bolted onto a fixated plate or block placed under a loose rectangular bar. The sliding clamp cannot move but the bar can be slid up and down over the fixated plate or block.

Drawing reference:

- 1) Leaf spring
- 2) Reading line for scales

Sliding clamp for square bars, knob orange

Drawings

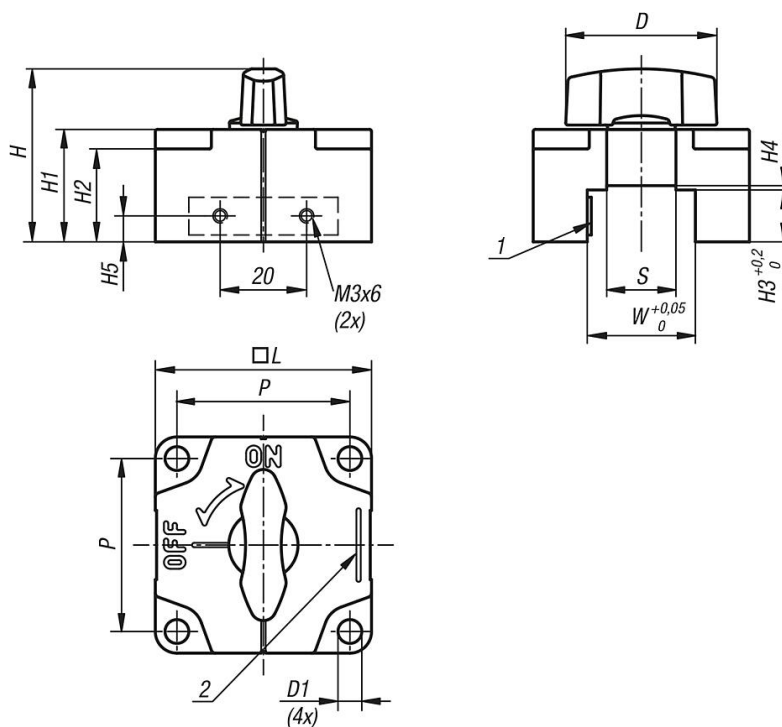

Installation dimensions counterpart square bar

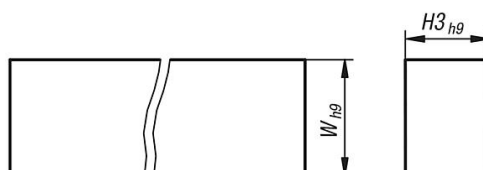

Order No.	Color	L	D	D1	H	H1	H2	H3	H4	H5	P	W	S	Holding force N	Temperature resistance
K1072.12122	orange	40	28	4,5	36	22	18,5	12	-	6	32	12	-	500	≤90 °C
K1072.16162	orange	40	28	4,5	40	26	22,5	16	-	8	32	16	-	500	≤90 °C
K1072.2592	orange	50	35	5,5	37	23	18,5	9	1	4,5	40	25	16	800	≤90 °C
K1072.25122	orange	50	35	5,5	40	26	21,5	12	1	6	40	25	16	800	≤90 °C
K1072.32122	orange	50	35	5,5	40	26	21,5	12	1	6	40	32	16	800	≤90 °C
K1072.32162	orange	50	35	5,5	44	30	25,5	16	1	8	40	32	16	800	≤90 °C